

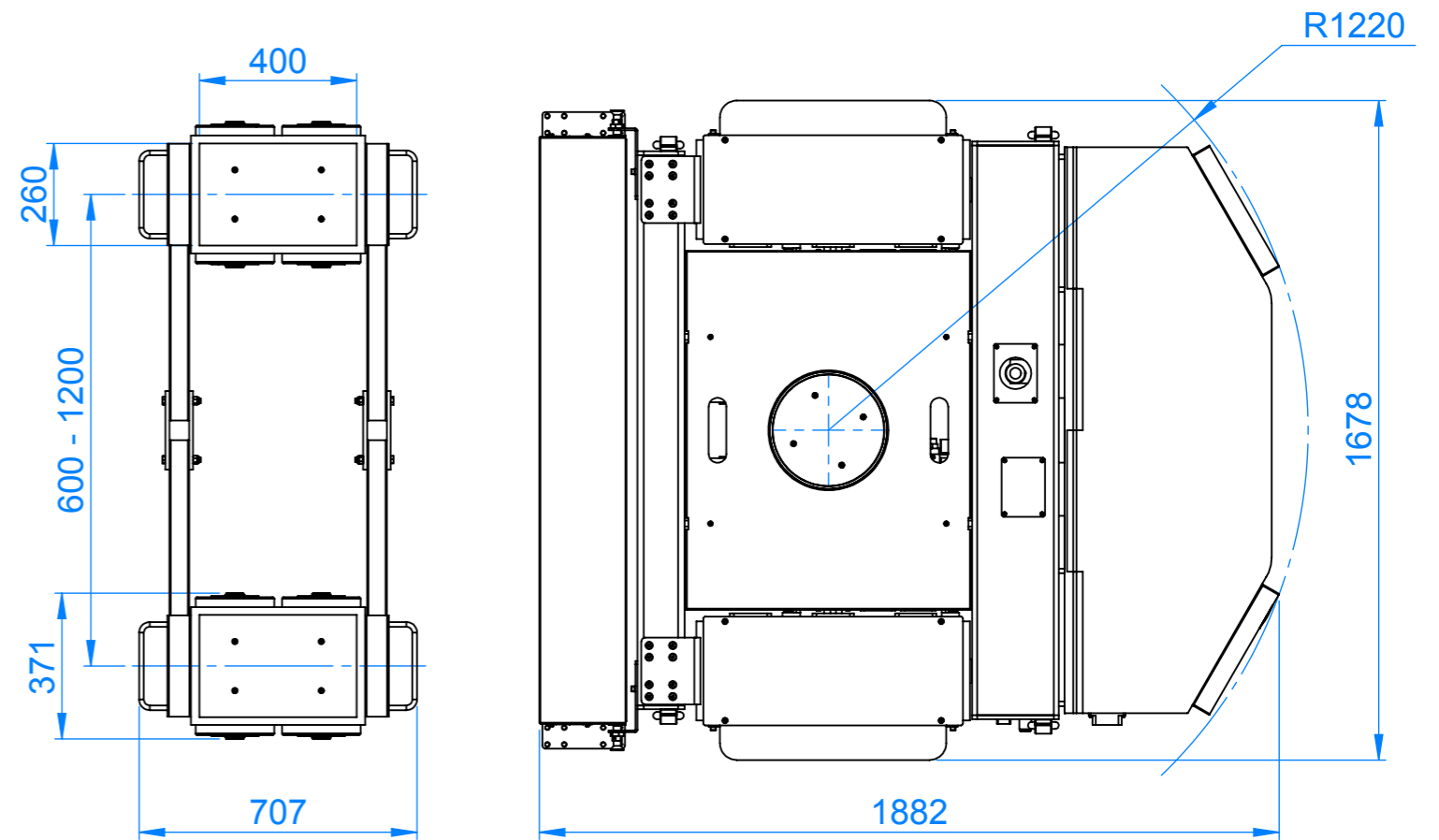

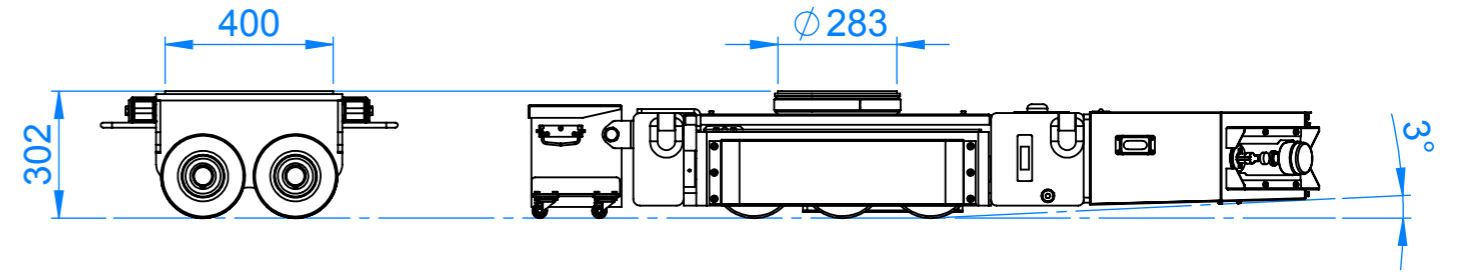

Confidential information, unauthorized use beyond OX-CFB trade relations. Información confidencial, no autorizado su uso fuera de la relación con OX-CFB.

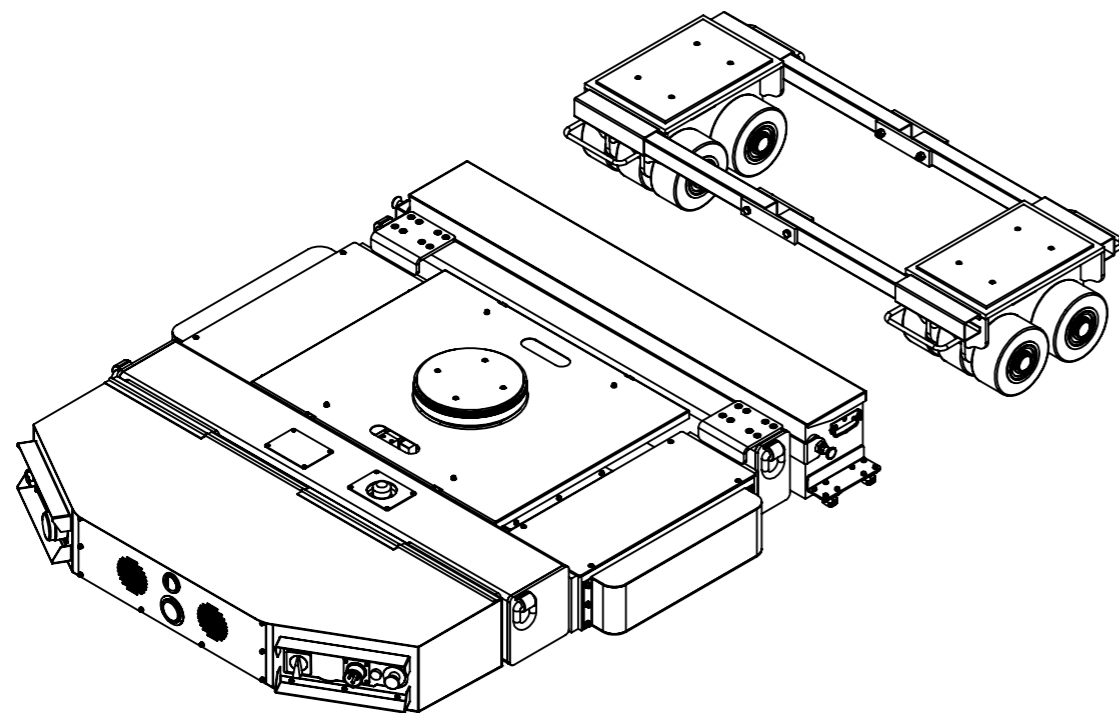

Name Nombre		Date Fecha	Client Cliente		 
Drawn Dibujado	D.D.M.	19/11/2019	General tolerance ISO 2768 / mK Tolerancia general	Sandblasting SA2 1/2 ISO 8501-1 Granallado	
Validated Validado	C.S.M.	19/11/2019	Surface finish ISO 1302 Acabado superficial	Paint quality C2 ISO 12944 Calidad pintura	Quantity Cantidad
Material Material		Treatment Tratamiento		Finish Acabado	Weight Peso
Scale Escala	Drawing title Título plano		TANQUETA + CARROS TRASEROS		Drawing n° N° plano
Project title Título proyecto		OX TBC 060 + OX CT 060		Revision n° N° revisión	A3
				Sheet n° N° hoja	

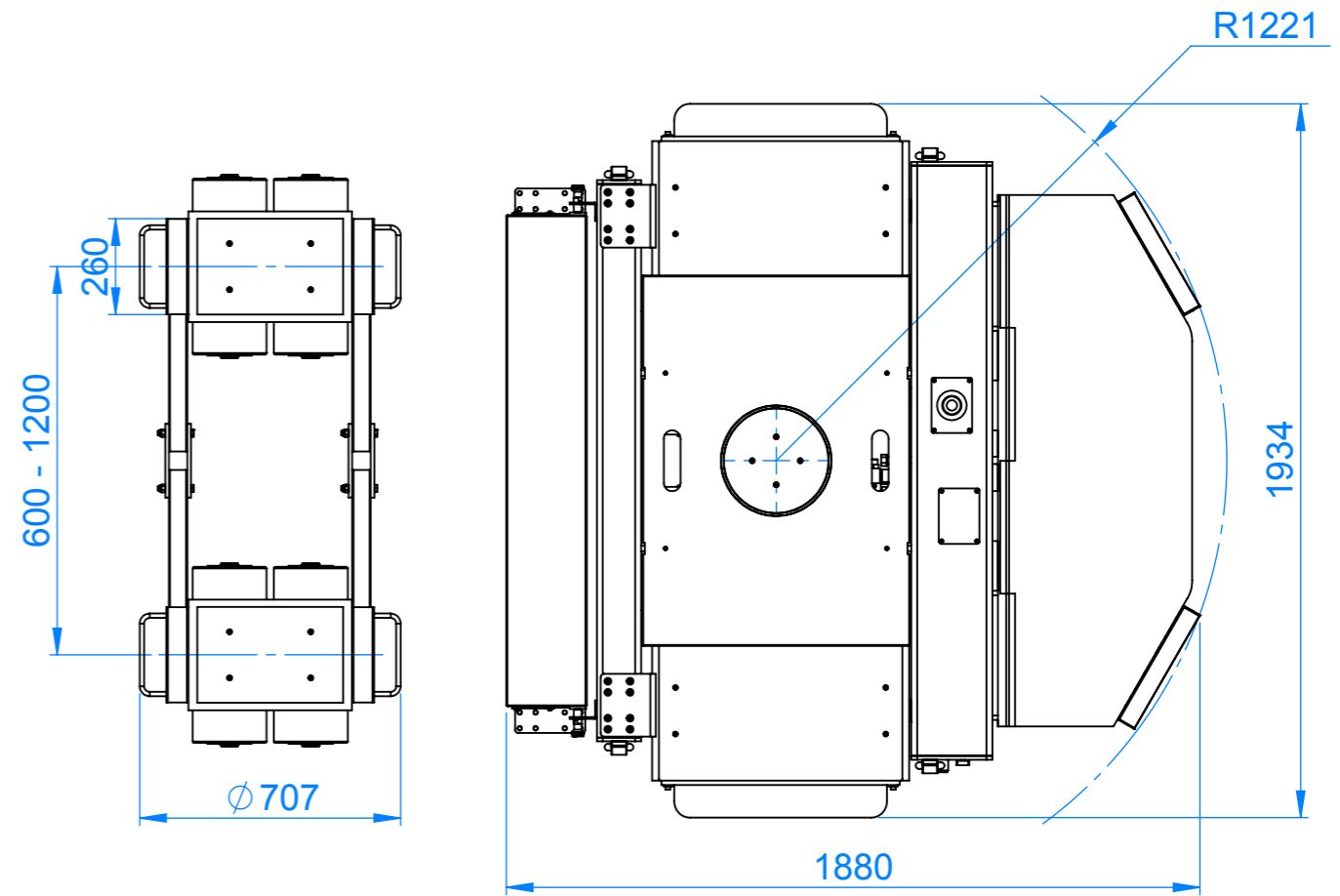
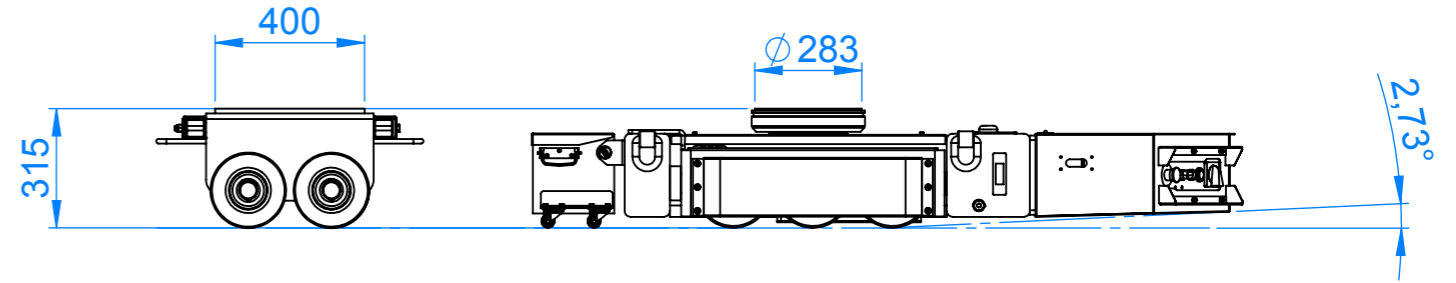
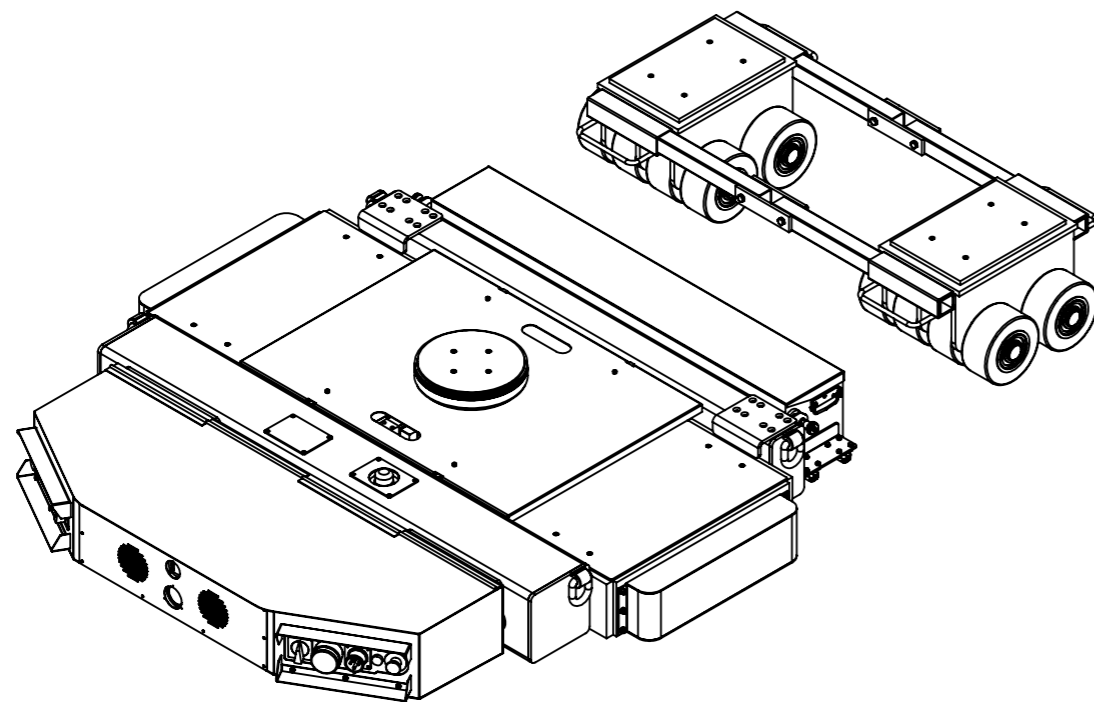
Confidential information, unauthorized use beyond OX-CFB trade relations. Información confidencial, no autorizado su uso fuera de la relación con OX-CFB.



Name Nombre		Date Fecha	Client Cliente		--		 	
Drawn Dibujado	D.D.M.	25/09/2018	General tolerance ISO 2768 / mK Tolerancia general	Sandblasting SA2 ISO 8501-1 Granallado				
Validated Validado	C.S.M.	25/09/2018	Surface finish ISO 1302 Acabado superficial	Paint quality C2 ISO 12944 Calidad pintura				
Material Material			Welding requirements ISO 5817 / B Requisitos soldadura	Medium durability ISO 12944 Durabilidad media	Quantity Cantidad	---		
Scale Escala			Treatment Tratamiento	Finish Acabado	Weight Peso	1350 kg aprox		
Drawing title Título plano		TANQUETA + CARROS TRASEROS		Drawing nº Nº plano				
Project title Título proyecto		OX TBC 100 + OX CT 100		Revision nº 00 Nº revisión				
				Sheet nº 1 / 1 Nº hoja		A3		