

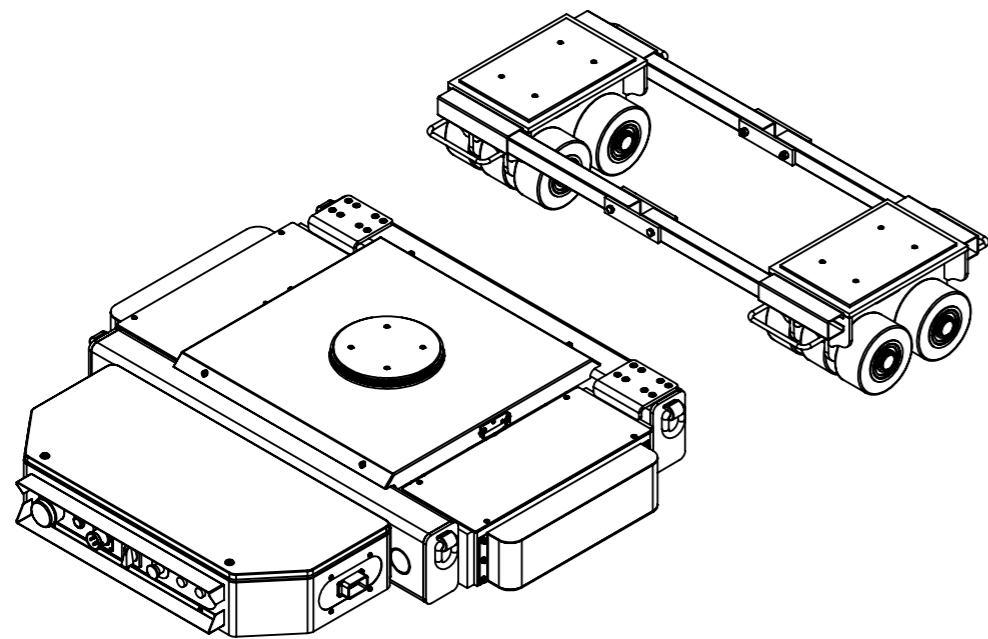

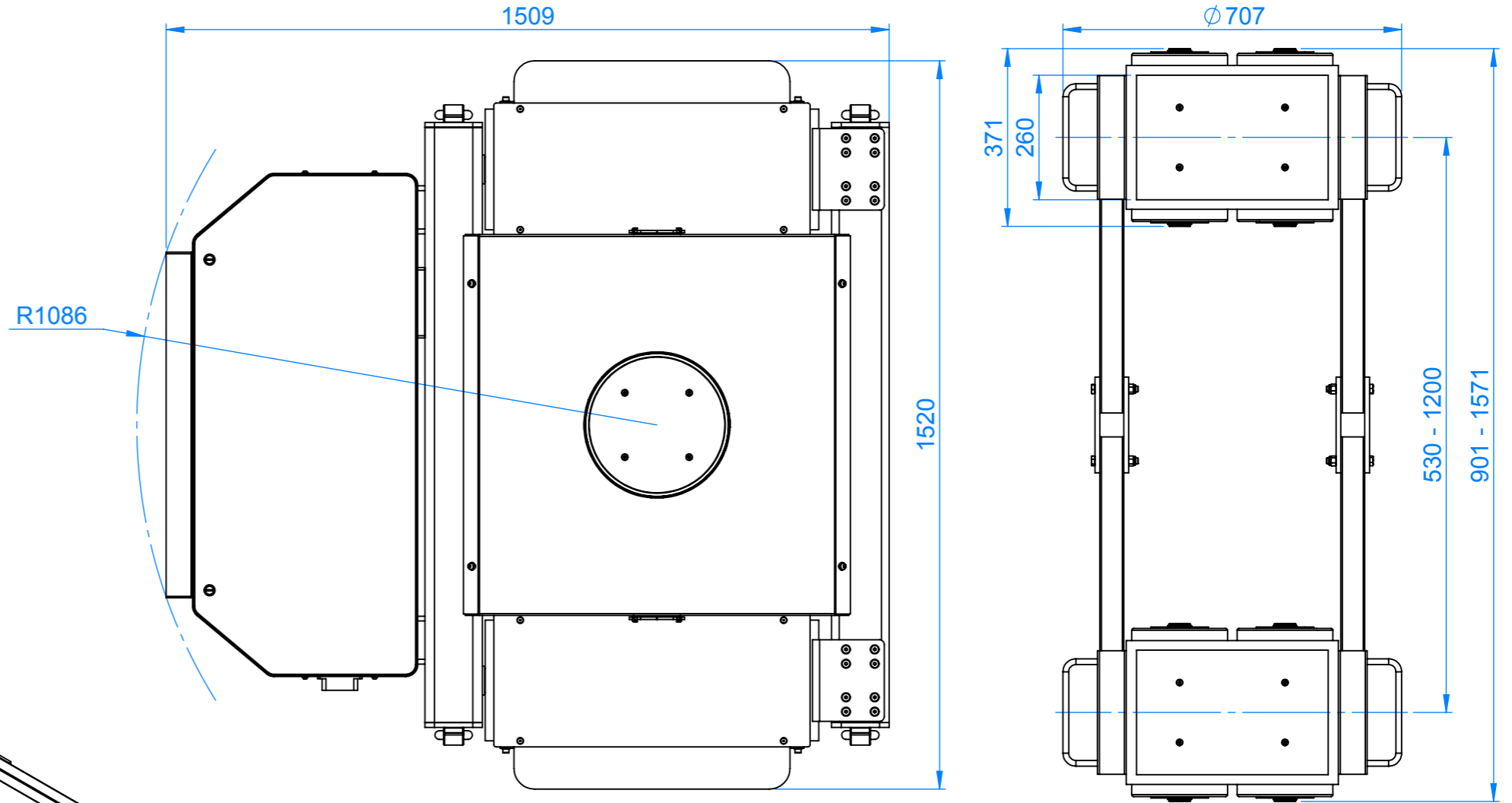

Confidential information, unauthorized use beyond OX-CFB trade relations. Información confidencial, no autorizado su uso fuera de la relación con OX-CFB.

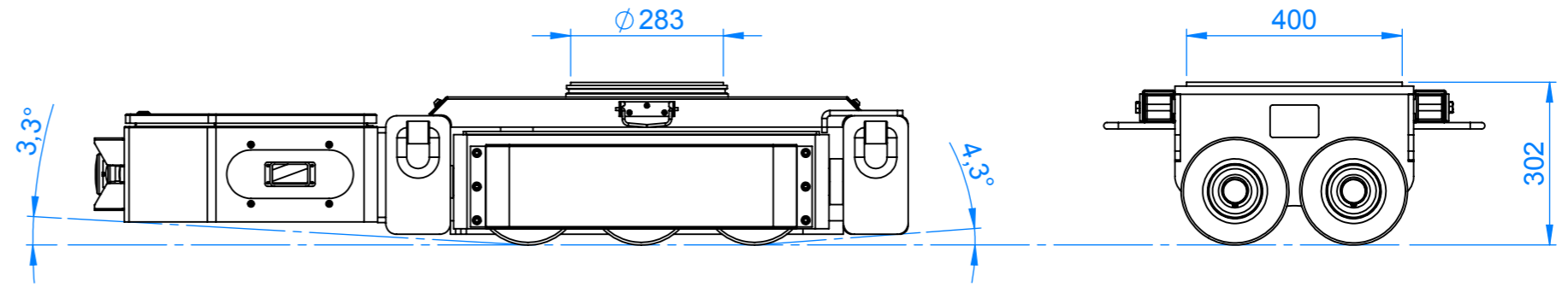

	Name Nombre	Date Fecha	Client Cliente			 
Drawn Dibujado	D.D.M.	08/10/2019	General tolerance ISO 2768 / mK Tolerancia general	Sandblasting SA2 1/2 ISO 8501-1 Granallado		
Validated Validado	C.S.M.	08/10/2019	Surface finish ISO 1302 Acabado superficial	Paint quality C2 ISO 12944 Calidad pintura		Quantity Cantidad
Material Material			Welding requirements ISO 5817 / D Requisitos soldadura	Medium durability ISO 12944 Durabilidad media		Weight Peso
Scale Escala	Drawing title Título plano		Treatment Tratamiento	Finish Acabado	Drawing n° N° plano	
	Project title Título proyecto		Tanqueta + Carros traseros			Revision n° N° revisión
			OX ST1 060 + CT 060			Sheet n° N° hoja
						1 / 1
						A3

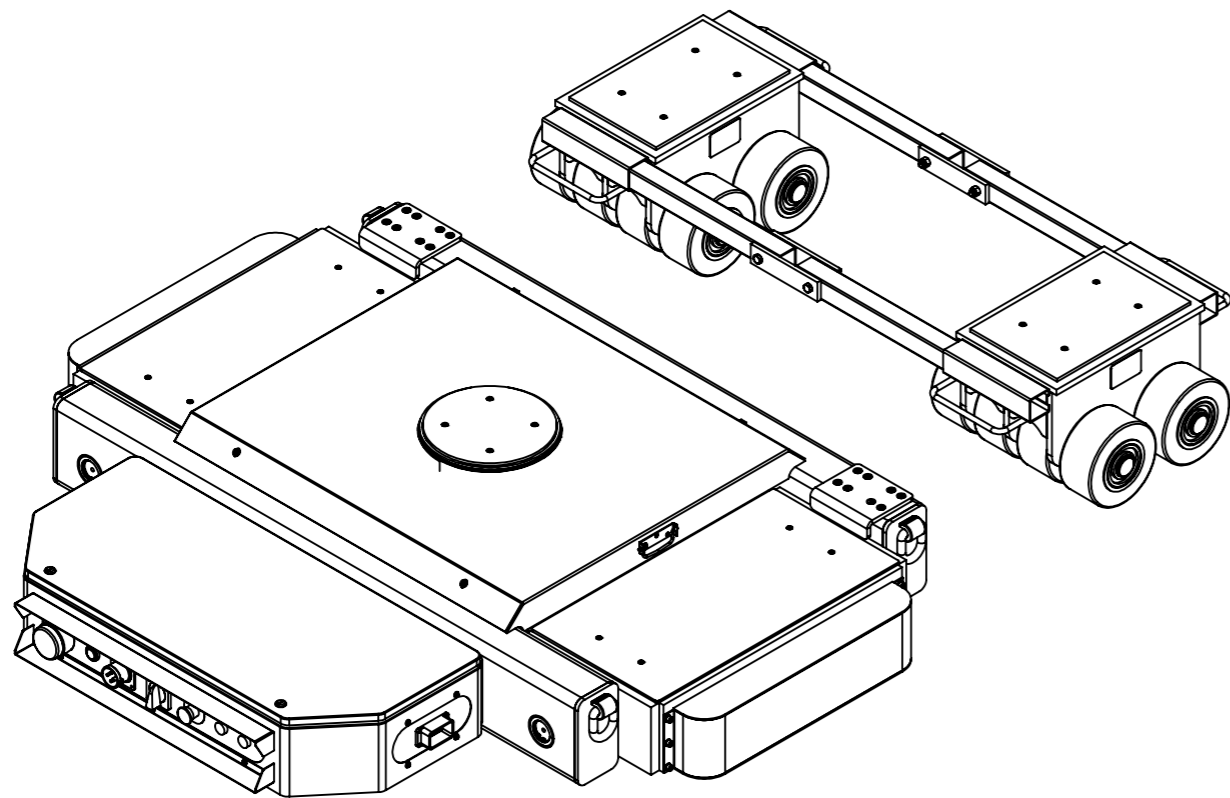
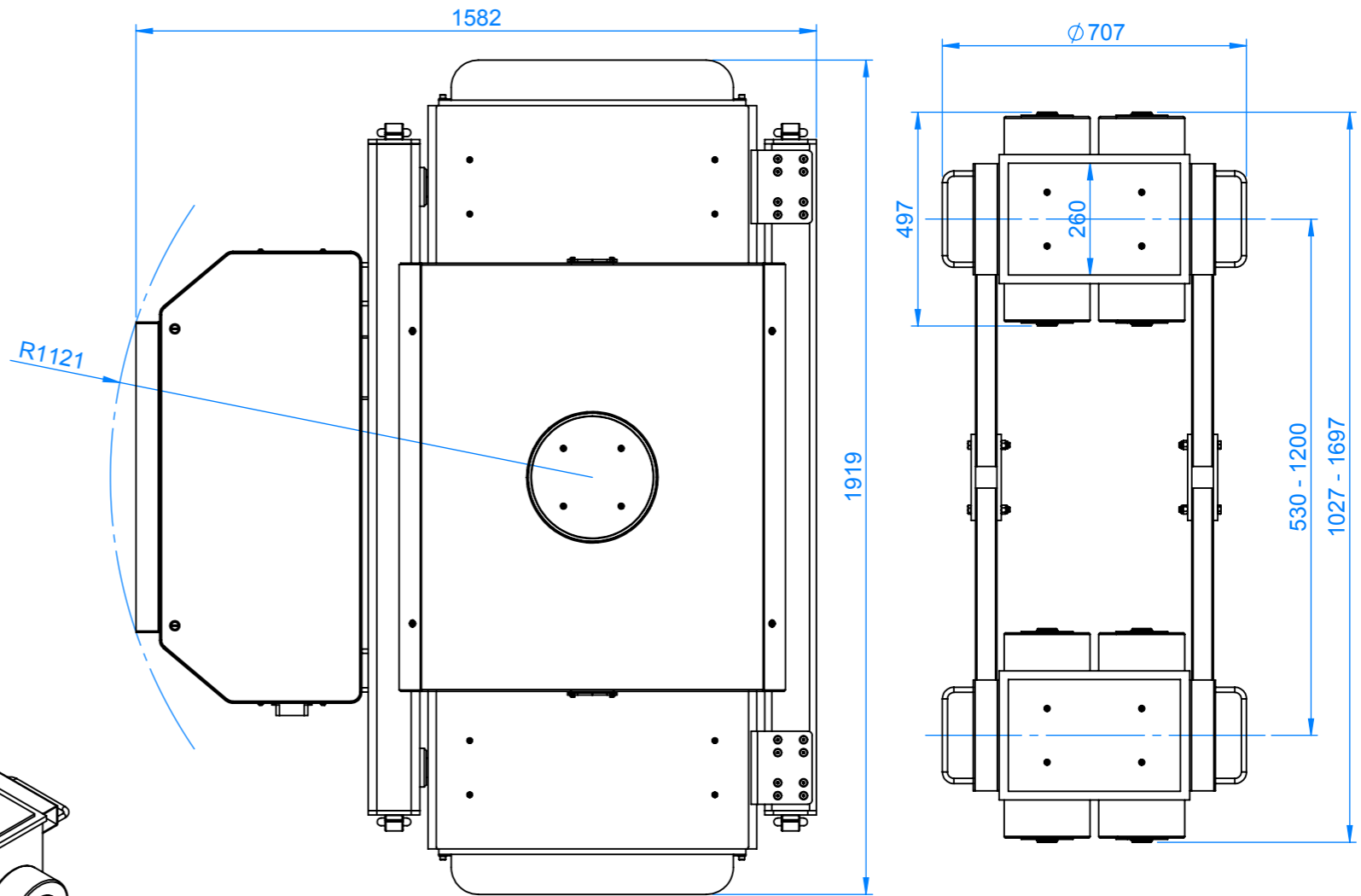
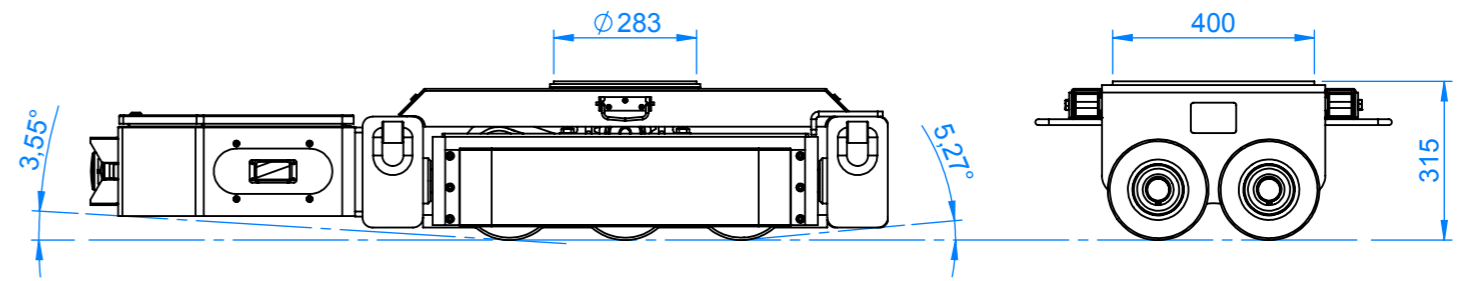
Confidential information, unauthorized use beyond OX-CFB trade relations. Información confidencial, no autorizado su uso fuera de la relación con OX-CFB.



	Name Nombre	Date Fecha	Client Cliente			 
Drawn Dibujado	D.D.M.	15/10/2021	General tolerance ISO 2768 / mK Tolerancia general	Sandblasting SA2 1/2 ISO 8501-1 Granallado		
Validated Validado	C.S.M.	15/10/2021	Surface finish ISO 1302 Acabado superficial	Paint quality C2 ISO 12944 Calidad pintura		Quantity Cantidad
Material Material			Welding requirements ISO 5817 / D Requisitos soldadura	Medium durability ISO 12944 Durabilidad media		Weight Peso
Scale Escala	Drawing title Título plano		Treatment Tratamiento	Finish Acabado	Drawing n° N° plano	
	Project title Título proyecto		Tanqueta + Carros traseros			Revision n° N° revisión
			OX ST3 100 + CT 100			Sheet n° N° hoja
						1 / 1
						A3